

p

Series: MC Power
Round, Terminal Type

Ultra low internal resistance
Highest power performance available
Lowest RC time constant

› **Features:**

- › 2.7 Volt Operating Voltage
- › Ultra low internal resistance
- › Over 1 million duty cycles
- › Highest power performance available
- › Lowest RC time constant
- › Threaded terminal or weldable post versions

› **Applications:**

- › Hybrid drive trains
- › Automotive subsystems
- › Transportation
- › Rail system power



› **Overview:**

The Power-type ultracapacitor product line gives customers in the automotive and transportation sector a much wider range of choices to meet their energy storage and power delivery requirements.

The cells are specifically engineered for hybrid vehicle drive trains, automotive subsystems and other heavy duty applications that require the lowest equivalent series resistance (ESR) and highest efficiency available.

In addition to meeting or exceeding demanding automotive and transportation application requirements for both watt-hours of energy storage and watts of power delivery per kilogram, all of these products will perform reliably for more than one million discharge-recharge cycles.

The proprietary architecture and material science on which BOOSTCAP® products are based enable continued leadership in controlling costs, flexibility in product offerings and allow application specific performance tailoring. The cells operate at 2.7 volts, enabling them to store more energy and deliver more power per unit volume than any other commercially available ultracapacitor products.

> **MC Power Series Specifications:**

Item		Performance
Operating Temperature Range		-40 °C to +65 °C
Storage Temperature Range		-40 °C to +70 °C
Rated Voltage		2.7 V DC
Capacitance Tolerance		+20%
Resistance Tolerance		Max.
Temperature Characteristics	Capacitance Change	Within ± 5% of initial measured value at 25 °C (at -40 °C)
	Internal Resistance	Within 150% of initial measured value at 25 °C (at -40 °C)
Endurance	After 1500 hours application of rated voltage at 65 °C	
	Capacitance Change	Within 20% of initial specified value
	Internal Resistance	Within 60% of initial specified value
Shelf Life		After 1500 hours storage at 65 °C without load shall meet specification for endurance
Life Test	After 10 years at rated voltage and 25 °C	
	Capacitance Change	Within 30% of initial specified value
	Internal Resistance	Within 150% of initial specified value
Cycle Test	Capacitors cycled between specified voltage and half rated voltage under constant current at 25 °C (1 million)	
	Capacitance Change	Within 30% of initial specified value
	Internal Resistance	Within 150% of initial specified value

> **MC Power Product Specifications:**

Part Number	Capacitance (F)	ESR, DC (mohm)	ESR, 1kHz (mohm)	Ic (mA)
BCAP0650 P270	650	0.80	0.60	1.5
BCAP1200 P270	1200	0.58	0.44	2.7
BCAP1500 P270	1500	0.47	0.35	3.0
BCAP2000 P270	2000	0.35	0.26	4.2
BCAP2600 P270	2600	0.31	0.23	5.2

> **MC Power Product Properties:**

Maxwell Part No.	Rt (C/W)	Isc (A)	Emax (Wh/kg)	Pmax (W/kg)	Pd (W/kg)
BCAP0650 P270	6.5	3500	3.29	15,100	5,400
BCAP1200 P270	5.3	3750	4.05	13,800	5,000
BCAP1500 P270	4.5	3900	4.75	16,200	5,800
BCAP2000 P270	3.8	4300	5.06	17,500	6,200
BCAP2600 P270	3.0	4800	5.72	17,200	6,100

› **Dimensions:**

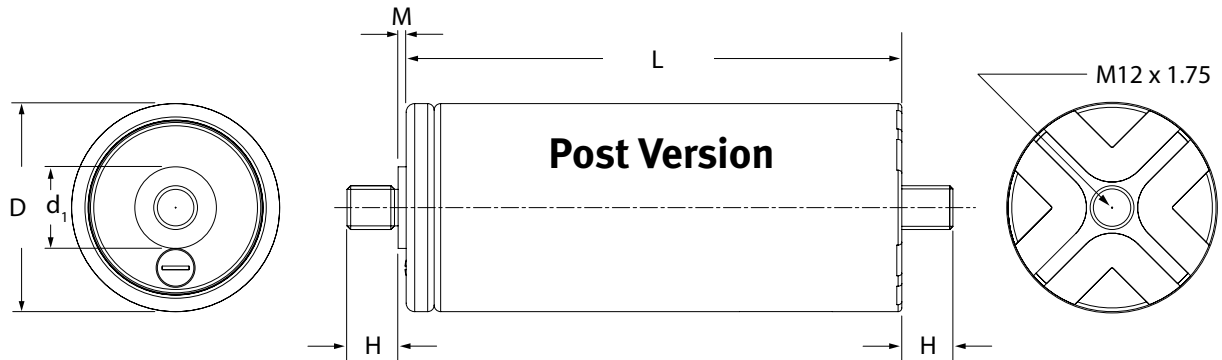

Part Number	Vol (l)	Mass (kg)	Size (mm)				
			L	M	H	D	d ₁
BCAP0650 P270 T04	0.211	0.20	44.5	2.0	14.0	60.0	22.4
BCAP1200 P270 T04	0.294	0.30	74.0	2.0	14.0	60.0	22.4
BCAP1500 P270 T04	0.325	0.32	85.0	2.0	14.0	60.0	22.4
BCAP2000 P270 T04	0.373	0.40	102.0	2.0	14.0	60.0	22.4
BCAP2600 P270 T04	0.439	0.46	138.0	2.0	14.0	57.7	22.4

Product dimensions and specifications may change without notice. Please contact Maxwell Technologies directly for any technical specifications critical to application.

› **Mounting Recommendations:**

Do not reverse polarity.

Maximum torque for M12 screw terminals are 10Nm.

Cells are designed to be connected into series or parallel strings.

Worldwide Headquarters

MAXWELL TECHNOLOGIES
 9244 Balboa Avenue • San Diego, 92123 CA, USA
 PHONE: +(1) 858 503 3300
 FAX: +(1) 858 503 3301
 EMAIL: info@maxwell.com

European Office

MAXWELL TECHNOLOGIES SA
 CH-1728 Rossens • Switzerland
 PHONE: +41 (0) 26 411 85 00
 FAX: +41 (0) 26 411 85 05
 EMAIL: info@maxwell.com

› **Dimensions:**

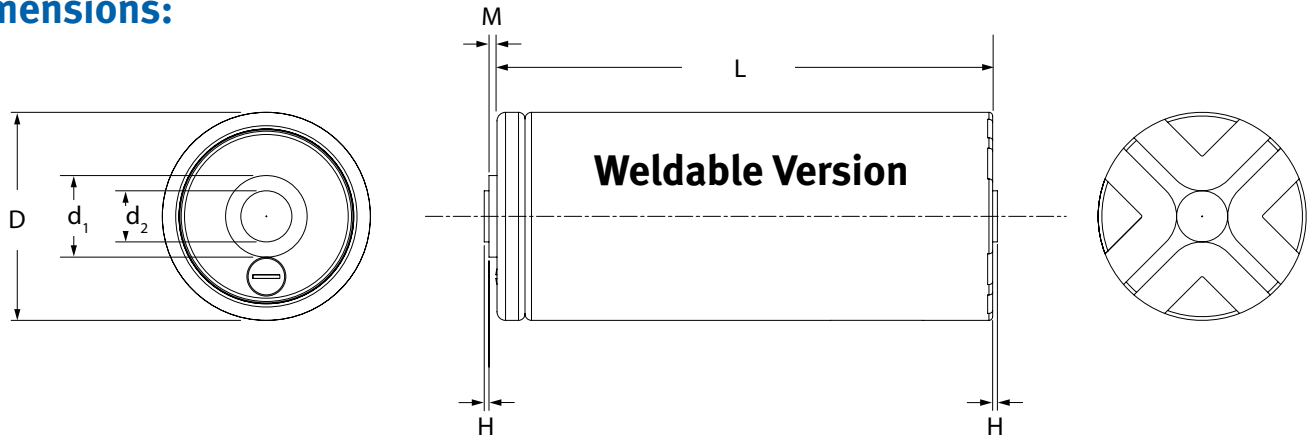

Part Number	Vol (l)	Mass (kg)	Size (mm)					
			L	M	H	D	d ₁	d ₂
BCAP0650 P270 T05	0.150	0.20	44.5	2.0	3.20	60.0	22.4	14.0
BCAP1200 P270 T05	0.233	0.30	74.0	2.0	3.20	60.0	22.4	14.0
BCAP1500 P270 T05	0.264	0.32	85.0	2.0	3.20	60.0	22.4	14.0
BCAP2000 P270 T05	0.312	0.40	102.0	2.0	3.20	60.0	22.4	14.0
BCAP2600 P270 T05	0.383	0.46	138.0	2.0	3.20	57.7	22.4	14.0

Product dimensions and specifications may change without notice. Please contact Maxwell Technologies directly for any technical specifications critical to application.

› **Markings:**

Capacitors are marked with the following information - Rated capacitance and rated voltage as well as energy/power type indication in the product naming. Serial number, name of manufacturer, positive and negative terminal, warning marking.

› **Additional Technical Information:**

Capacitance and ESR, DC measured per document 1007239

I_c = Leakage current after 72 hours, 25°C I_{sc} = short circuit current (maximum peak current)

R_t = Thermal resistance

$$E_{max} = \frac{\frac{1}{2} CV^2}{3600 \times mass} \qquad P_{max} = \frac{V^2}{4R(1kHz) \times mass} \qquad P_d = \frac{0.12V^2}{R(DC) \times mass}$$

Patent Pending

Worldwide Headquarters

MAXWELL TECHNOLOGIES
9244 Balboa Avenue • San Diego, 92123 CA, USA
PHONE: + (1) 858 503 3300
FAX: + (1) 858 503 3301
EMAIL: info@maxwell.com

European Office

MAXWELL TECHNOLOGIES SA
CH-1728 Rossens • Switzerland
PHONE: +41 (0) 26 411 85 00
FAX: +41 (0) 26 411 85 05
EMAIL: info@maxwell.com



www.maxwell.com

Disclaimer of Warranty/Limitation of Liability for Uses in Life Support Devices or Critical Systems

Maxwell Technologies, Inc. and its Affiliates (“Maxwell”) provide no warranties of any kind either express or implied, including (without limitation) the implied warranties of merchantability and fitness, for uses of its products as components in life support devices or critical systems.

“Life support devices” are devices or systems, which (a) are intended for surgical implant into a living body, or (b) support or sustain life, and whose failure to perform when properly used in accordance with the instructions provided in the labeling can be reasonably expected to result in bodily injury to the user. An example of a life support device includes, but is not limited to, a heart pacemaker.

A “critical system” is any system whose failure to perform can affect the safety or effectiveness of a higher level system, or cause bodily or property injury by loss of control of the higher level device or system. An example of a critical system includes, but is not limited to, aircraft avionics.

You agree that Maxwell will not be liable to you for any loss or damages, either actual or consequential, indirect, punitive, special, or incidental, arising out of or relating to these terms.

These terms are a non-waivable condition to any contract that Maxwell may enter into. An exception to these terms may only be authorized in a writing signed by the President of Maxwell or a duly authorized officer.

Patent Pending

Worldwide Headquarters

MAXWELL TECHNOLOGIES
9244 Balboa Avenue • San Diego, 92123 CA, USA
PHONE: +(1) 858 503 3300
FAX: +(1) 858 503 3301
EMAIL: info@maxwell.com

European Office

MAXWELL TECHNOLOGIES SA
CH-1728 Rossens • Switzerland
PHONE: +41 (0) 26 411 85 00
FAX: +41 (0) 26 411 85 05
EMAIL: info@maxwell.com

Maxwell
TECHNOLOGIES
www.maxwell.com